

## Size of JPH series

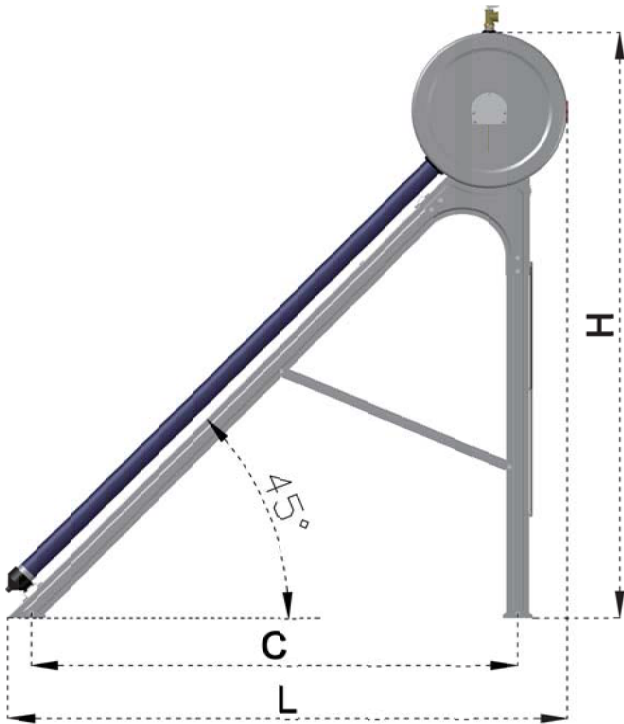

NO.	Model	Capacity(L)	Tank Dia.(mm)	Tube size			Figure Size (L×W×H)(mm)	Installation (A×C) (mm)
				Qty.(pcs)	Dia.(mm)	Len.(mm)		
1	JPH-15	150	460/ 360	15	58	1800	1640×1330×1720	1110×1480
2	JPH-20	200	460/ 360	20	58	1800	1640×1705×1720	1485×1480
3	JPH-30	300	460/ 360	30	58	1800	1640×2455×1720	2235×1480